

Carefully read the centrifuge instruction manual and the rotor instruction manual before using the rotor.

S58A Angle rotor

Max. speed 58,000 rpm
 Max. R.C.F. 289,000 × g
 Rotor nominal capacity 108mL=13.5mL × 8
 k factor 50

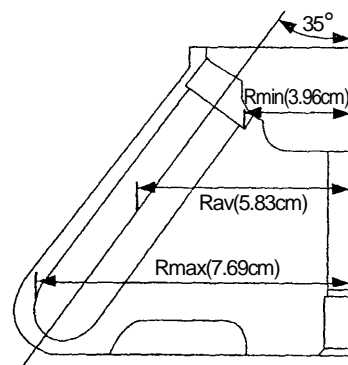

(1) Summary of tubes

Tube·Bottle					Adapter		Cap		Maximum speed (rpm)	Maximum R.C.F. (× g)
Nominal capacity	Part No.	Name	Size (φ×L cm)	Net Capacity (mL)	Part No.	Name	Part No.	Name		
13.5	345320A	12PA Seal tube	1.6×7.8	13.5	-----		486582	C2 space cap	58,000	289,000
	(S302894A)	(12PA Re-seal tube)	1.6×7.8	13.5	-----		(S405437A)	(Crown C2)	58,000	289,000
12	329606A	12PA Tube	1.6×7.6	10.5	-----		463577A	C-TI cap ass'y	58,000	289,000
				10.2	-----		S410542A	S-12AL cap ass'y	58,000	289,000
	325470A	12PE Tube	1.6×7.5	10.5	-----		463577A	C-TI cap ass'y	58,000	289,000
				10.0	-----		S410542A	S-12AL cap ass'y	58,000	289,000
	325751A	12PC Tube	1.6×7.6	10.5	-----		463577A	C-TI cap ass'y	58,000	289,000
	(669700-2080)	(Ultra-Lok™ tube)	1.6×7.6	10.1	-----		(S304733)	(Spacer)	58,000	289,000
326010A	12SS Tube	1.6×7.6	10.5	-----		463577A	C-TI cap ass'y	30,000	77,400	
			9.5	-----		-----	-----	35,000	105,000	
10	338455A	10PC Thick-walled tube	1.6×7.7	7.3	-----		-----	-----	58,000	289,000
	338456A	10PA Thick-walled tube	1.6×7.6	7.2	-----		-----	-----	50,000	215,000
	S303922A	10PC Bottle (B) ass'y	1.6×8.2	9.0	-----		-----	-----	58,000	289,000
	325952A	10PC Bottle ass'y	1.6×8.2	8.5	-----		-----	-----	55,000	260,000
	334105A	10PA Bottle ass'y	1.6×8.2	8.0	-----		-----	-----	50,000	215,000
6.5	329445A	6.5PA Tube	1.3×6.4	5.8	336687A	6.5A12 Adapter	414429A	B-AL cap ass'y	38,000	114,000
	326415A	6.5PC Tube	1.3×6.4	5.8	336687A	6.5A12 Adapter	414429A	B-AL cap ass'y	38,000	114,000
5	332245A	5PA Tube	1.3×5.2	5	336686A	5A12 Adapter	414429A	B-AL cap ass'y	38,000	107,000
4.7	S303141A	4.7PC Thick-walled tube	1.3×6.4	3.4	336687A	6.5A12 Adapter	-----	-----	38,000	114,000
4	329561A	4PA Tube	1.1×6.0	4	336685A	4A12 Adapter	336711A	A3-AL cap ass'y	38,000	117,000
3	336708A	3PA Tube	1.1×4.7	3	336684A	3A12 Adapter	336711A	A3-AL cap ass'y	38,000	109,000
	S301599A	3PC Tube	1.3×5.1	2.6	336686A	5A12 Adapter	-----	-----	38,000	107,000
0.9	S304296A	0.9PC Thick-walled tube	0.8×5.0	0.9	336683A	2A12 Adapter	-----	-----	42,000	151,000

Products in parentheses are those of the supply discontinuance.

(2) Standard accessories

Part No.	Name	Qty
338455A	10PC Thick-walled tube	2 boxes (10 tubes/box)
8062270	O-ring	2
8062014	O-ring	2
452701	Tweezers	1
Common accessories of all rotors (see Appendix)		1

Carefully read the centrifuge instruction manual and the rotor instruction manual before using the rotor.

(3) Separation characteristics table

Speed (rpm)	Max. R.C.F.(xg)			k factor
	Rmin (3.96cm)	Rav (5.83cm)	Rmax (7.69cm)	
10,000	4,430	6,520	8,600	1,681
15,000	9,960	14,700	19,300	747
20,000	17,700	26,100	34,400	420
25,000	27,700	40,700	53,700	269
30,000	39,800	58,700	77,400	187
35,000	54,200	79,800	105,000	137
40,000	70,800	104,000	138,000	105
45,000	89,700	132,000	174,000	83
50,000	111,000	163,000	215,000	67
55,000	134,000	197,000	260,000	56
58,000	149,000	219,000	289,000	50

When using 12PA Seal tube, the following parts are required.

- 12PA Seal tube kit (part No. S304991D)
[Components]
 - (a) 345320A 12PA Seal tube × 2 boxes (50 tubes/box)
 - (b) 486582 C2-space cap × 8
 - (c) S407157 Tube setter × 1

*If you do not have a Tube sealer, the following parts are also necessary.

- STF3 Tube sealer (901325)
- Tube rack (C) (S201778B)

When using 12PA Tube, the following parts are required.

- 12PA Tube kit (part no.S304986C)
[Components]
 - (a) 329606A 12PA Tube × 2 boxes (50 tubes/box)
 - (b) 463577A C-TI cap × 8
 - (c) S401803A Packing for cap × 2 boxes (10 tubes/box)
 - (d) 333885A Tube vice (C2) × 1
 - (e) 469283 Torque wrench × 1
 - (f) 435823A Tube setter × 1

When using C-TI caps for 12PE Tubes or 12PC Tubes, the following parts are required.

- Tool set (C2) (part no.341109A)
[Components]
 - (a) 333885A Tube vice (C2) × 1
 - (b) 469283 Torque wrench × 1
- Tube setter(C) (part no. 481056A)

When using S-12AL Caps for 12PA Tubes or 12PE Tubes, the following parts are required.

A S-12AL Cap can not be used for a 12PC Tube.

- S-12AL Cap tool set (part no.S308626A)
[Components]
 - (a) S410542A S-12AL Cap × 8
 - (b) S204591A Hand press × 1
 - (c) S411487 Tube holder(C) × 1
 - (d) S411486 Tube holder(E) × 1
 - (e) 481056A Tube setter(C) × 1